

FPT Automotive

THE FUTURE of driving is **NOW**



CEO Message

Inspired by the legendary unity of Lạc Long Quân and Âu Cơ, FPT Automotive's "Accelerate SDV" celebrates the collaboration of software and hardware partners to shape the future of automotive technology-one 'digital egg' at a time. This concept underscores our commitment to co-creation and innovation, uniting industry leaders to hatch new possibilities in mobility.

Our mission is to empower the evolution of software-defined vehicles (SDV) with advanced AI-driven solutions, connectivity, and real-time diagnostics. Guided by nearly two decades of expertise, we envision a future where cutting-edge automotive technologies not only transform driving experiences but also foster a smarter, safer, and more sustainable world.



“
*Together, we're accelerating
toward a new era of mobility.*

Industry Context

Industry Megatrends

The automobile industry is facing new challenges

Technological disruption, mounting regulatory and social pressures, and higher consumer expectations are forcing the industry to become more proactive and innovative than ever before.

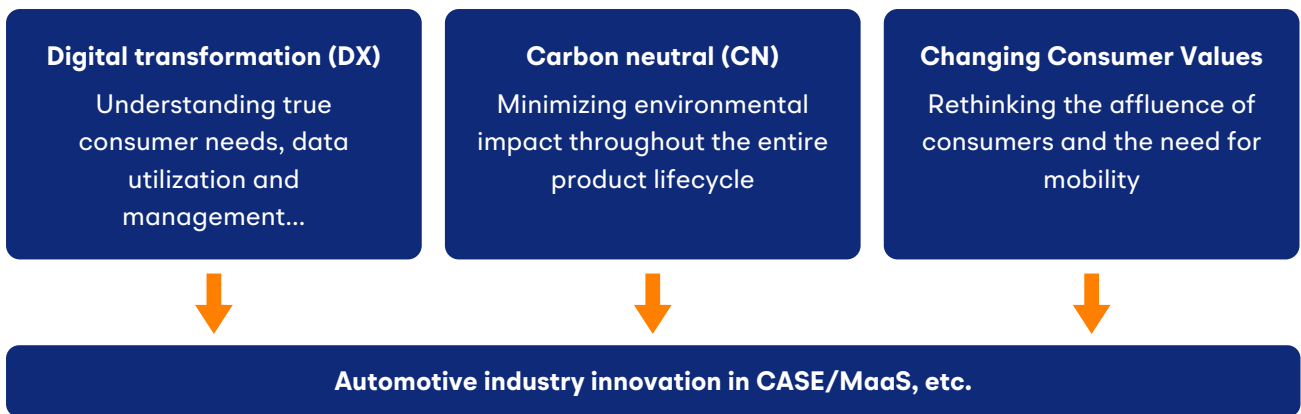





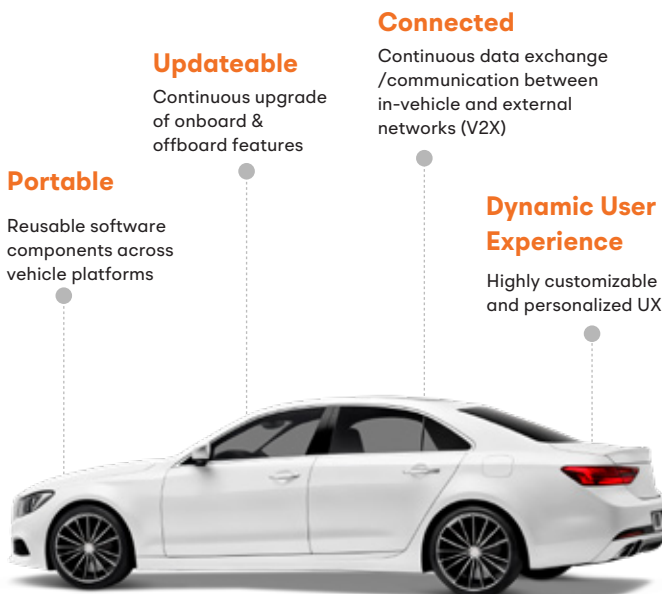

Source: Excerpt from the Japan Automobile Manufacturers Association Mobility Vision 2050 (revised medium- to long-term mobility vision) materials

Software Becoming the Primary Driver of Differentiation

Software Redefining the Characteristics of the Vehicle



-  Transition to centralized compute platforms (**HPCs**) with a **zonal-based architecture**
-  **Loosely coupled** hardware and software layers to accelerate feature development
-  **Hardware abstraction** providing standardized interface
-  Modular **SOA** for software reusability
-  **Containerization** in vehicles/ cloud backend to run multiple applications on shared compute resources
-  Shift towards **Ethernet** based communication to enable flexible connectivity

Capabilities

Automotive service map

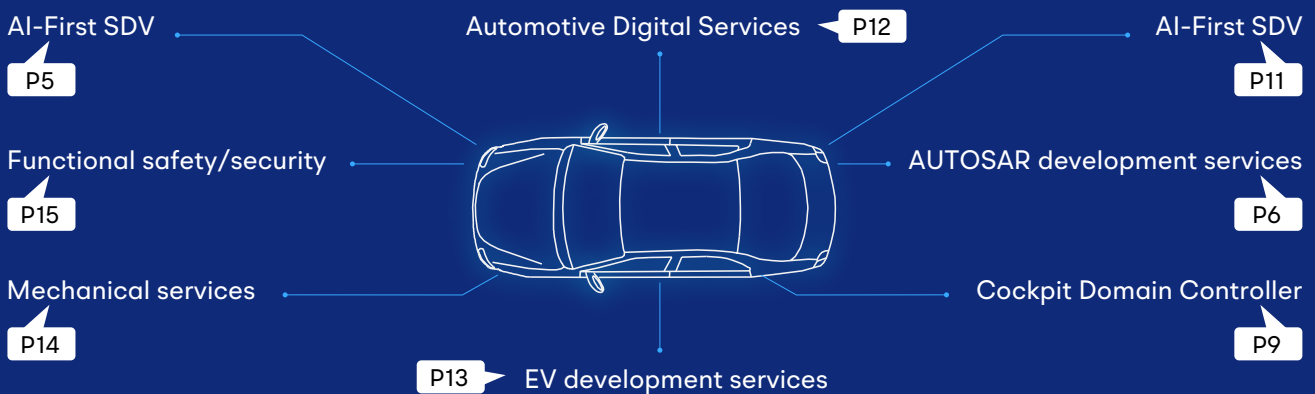

Why choose FPT's automotive development services?

For over two decades, FPT Automotive has been a trusted partner of world-leading automakers, OEMs, Tier-1 suppliers and semiconductor manufacturers. With accumulated knowledge on digital transformation and extensive know-how on the integration, development and deployment of advanced technologies, we help global automotive manufacturers achieve innovations and deliver next-generation vehicles.



Proven experiences

- 19+ years of experience in Automotive
- 17+ years of experiences in IVI
- 16+ years Platform (MCAL, BSW, SWC, Microcontrollers), tools, safety, R&D, etc. including compliance with ISO26262 A-SIL A/B/C/ D and A-SPIICE Level 3
- End-to-End turnkey solutions with ready-made platforms, tools, and services accelerating the AUTOSAR transformation
- CI/CD/DevOps as the de facto standard.
- 1,200+ AUTOSAR experts



High efficiency

- Faster time-to-market without sacrificing quality
- Big pool of 4000+ software engineers and parallel development for shorter project durations
- Cost competitiveness utilizing 20% of onshore resources +80% of total resources in Vietnam & other offshore bases
- Secure software services that take advantage of our broad experiences with the world's top chipmakers, tier-1 automotive suppliers, and OEMs.



Flexibility

- Adaptive to partner's frequent changes in requirements.
- Flexible working model: On-site, Offshore & Mix - Able to scale up at any time and anywhere
- Flexible business models: onshore/offshore hybrid



Service-Oriented Vehicle Diagnostics

THE FUTURE of car insights is **NOW**

As vehicle electronics evolve to support complex functions like autonomous driving, diagnostics are shifting from hardware checks to software-based assessments within high-performance computing environments. FPT's Service-Oriented Vehicle Diagnostics (SOVD) meets these demands with a hybrid server setup that ensures real-time diagnostics, seamless OTA updates, and remote troubleshooting. Our proprietary FPT-SOVD Agent enhances security, reduces data load, and eliminates the need for individual static servers, providing a cost-effective, future-ready solution for proactive vehicle management in today's advanced automotive landscape.

FPT Automotive’s early defect detection reduces warranty costs and minimizes downtime, streamlining operations. Additionally, our AI-driven remote diagnostics and subscription services open new revenue streams, providing clients with flexible, data-based solutions. By using a secure private server, we deliver a competitive edge, enhancing data security while keeping subscription fees low. This comprehensive approach sets our SOVD apart as an industry-leading solution.

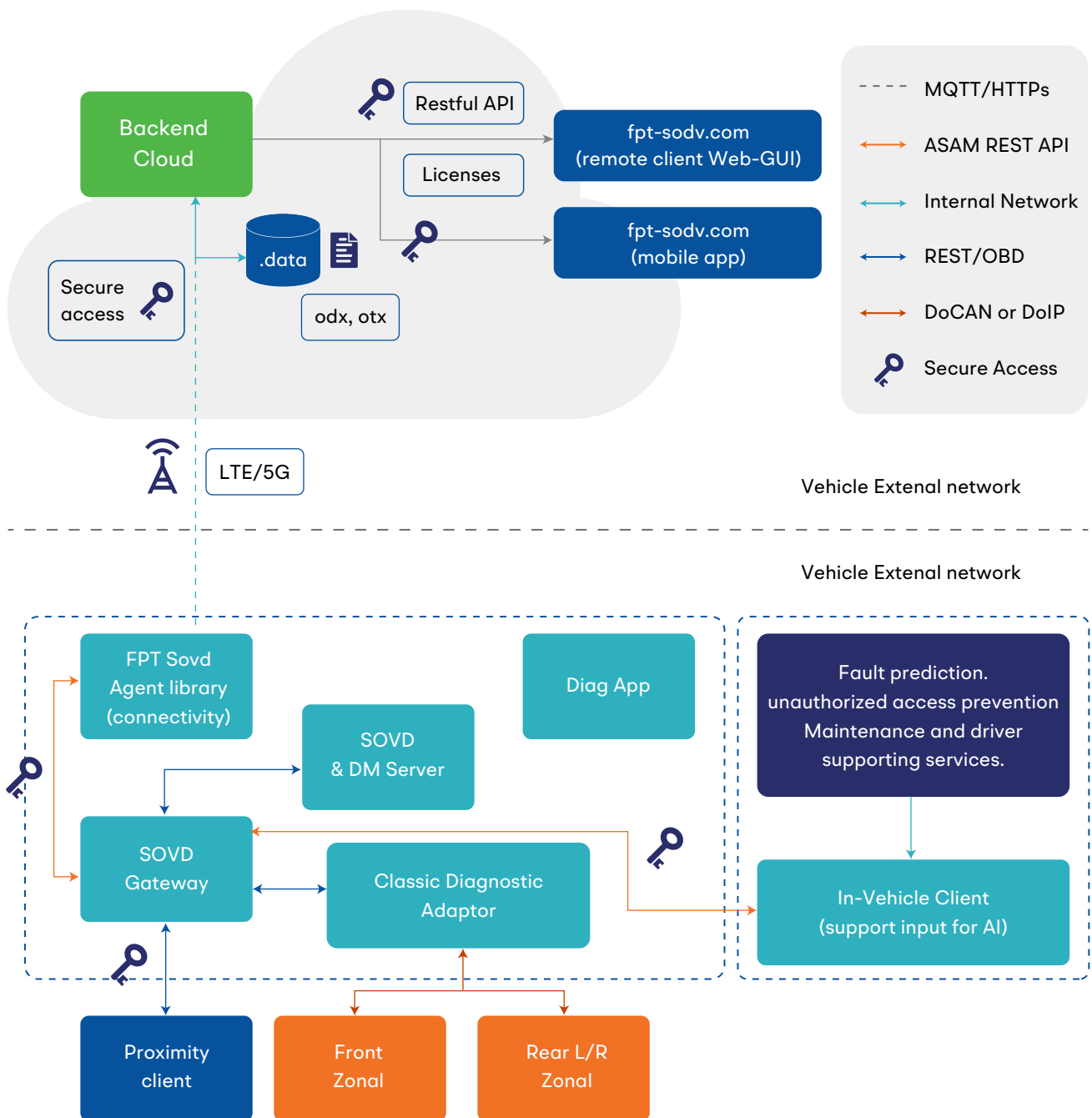



AI-First SDV

As the automotive industry accelerates toward a future defined by intelligent, connected, and personalized mobility, AI-driven solutions are essential in transforming the driving experience. Our AI-First SDV (Software-Defined Vehicle) solution is at the heart of this evolution, meeting the demand for seamless, adaptable, and user-centric vehicle technology. With advanced capabilities in AI integration, personalized assistance, intelligent safety monitoring, and an upgradable architecture, AI-First SDV enhances in-car experiences, boosts safety, and speeds time-to-market. Guided by the expertise of William Wei, FPT Automotive Executive Advisor, Former Foxconn CTO, our team is uniquely positioned at the forefront of next-generation automotive innovation.

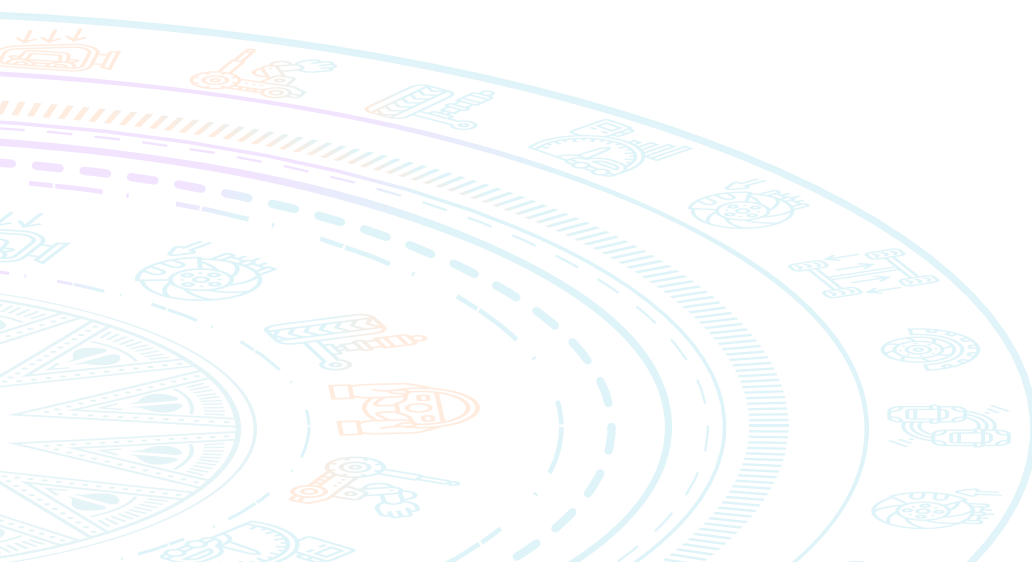
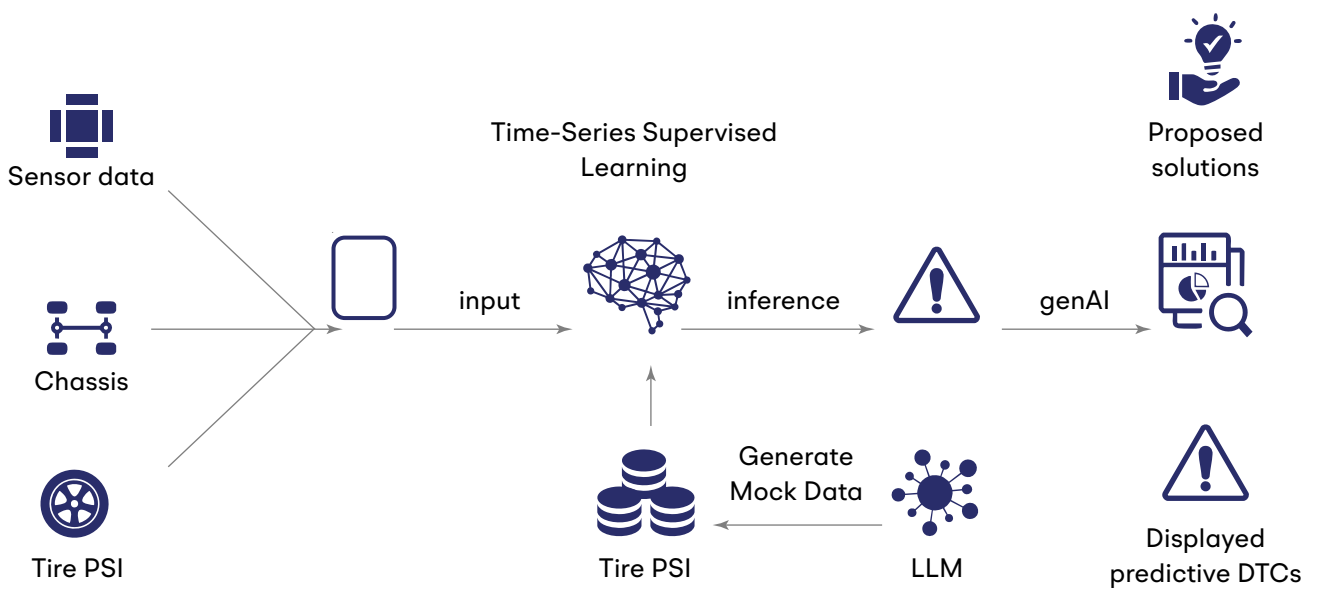
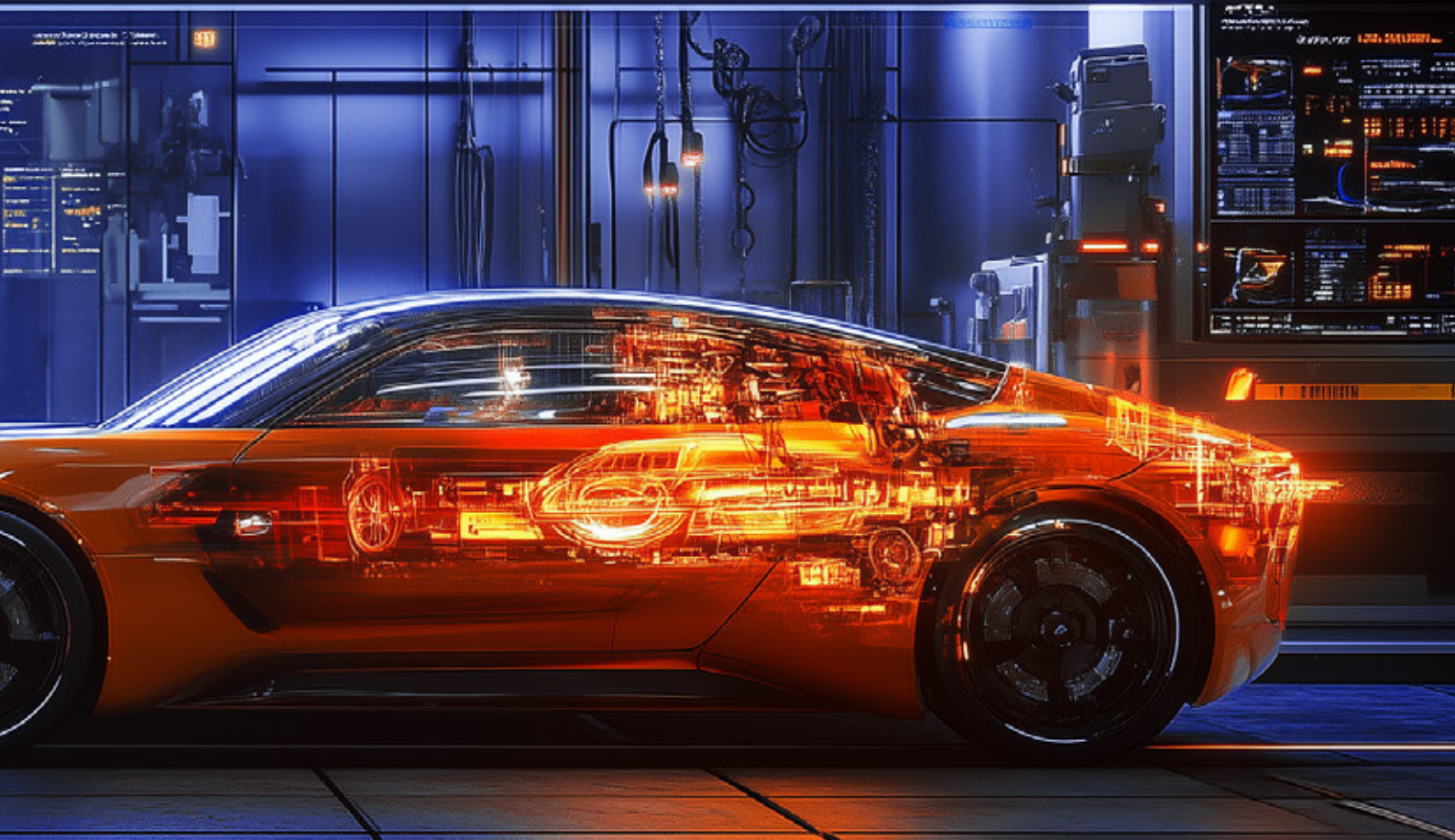



AI-First SDV

THE FUTURE
of driving is **NOW**

Why AI-First SDV?

■ Strong interests in GenAI adoption

75%

of surveyed automotive & manufacturing executives are experimenting with at least one GenAI application.

90%

of new vehicles sold globally to have built-in voice assistants by 2028.

■ AI drives critical automotive innovations

End-to-End AI

Is expected to deliver a new area for affordable self-driving L2+/L3

Transforming UX

with virtual personalized assistant, in-cabin comfort, energy management, traffic navigation and car health check.

GenAI-powered voice assistants

of new vehicles sold globally to have built-in voice assistants by 2028.



William Wei

Former CTO of Foxconn (2020-2022), he created the Open EV Platform MIH, heralded as the "Android of EVs"

At FPT Automotive, we're pioneering the future of driving with our AI-first SDV approach. Leveraging advanced AI models like OpenAI and Qrog, we're reshaping the driving experience with voice-activated controls for seamless adjustments to climate, navigation, and energy management—all designed with the user in mind.

Why Us for AI-First SDV?

Global AI Talent Human Resources

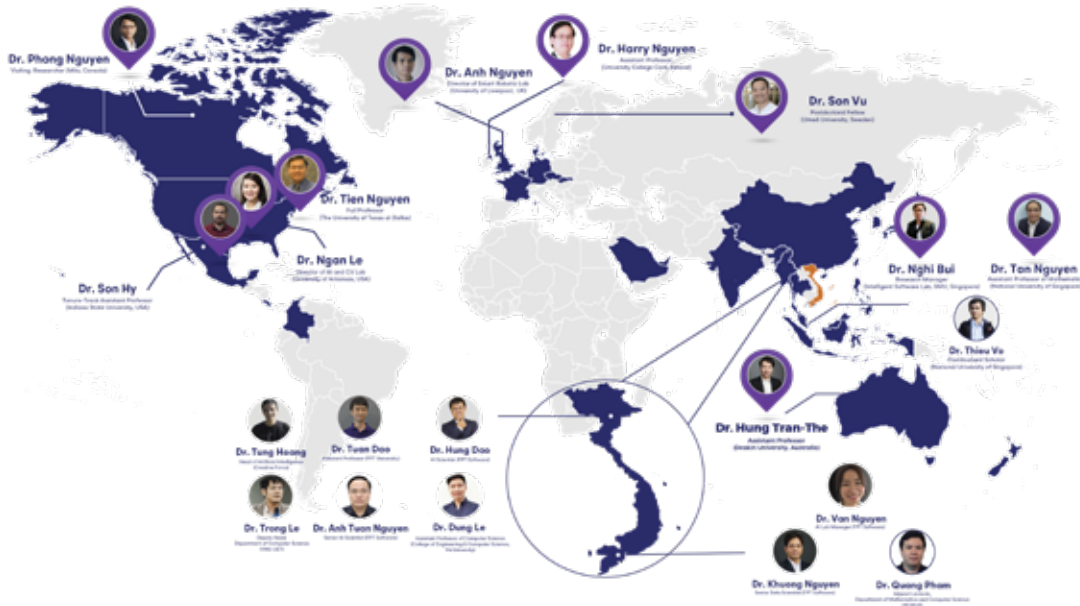

- 1.000+** AI Professionals
- 50+** AI Scientists
- 400+** AI Engineers
- 180+** Data Analysts
- 500+** Subject-matter experts
- 50+** Ph.D.
- 65** Accepted Papers
- 45** Top-tier *Publications



Strategic Partner



Infrastructure Data Center & Cloud Service

NVIDIA DGX H100
 Full scale Cloud based AI Service
 On-premises, hybrid, multi cloud,
 or at the edge-create secure,
 future-ready cloud solutions



Emerging AI Technology

AI Revolutionizes Software-Defined Vehicles (SDVS)

Large Language Model

Large Vision Model

Large Code Model

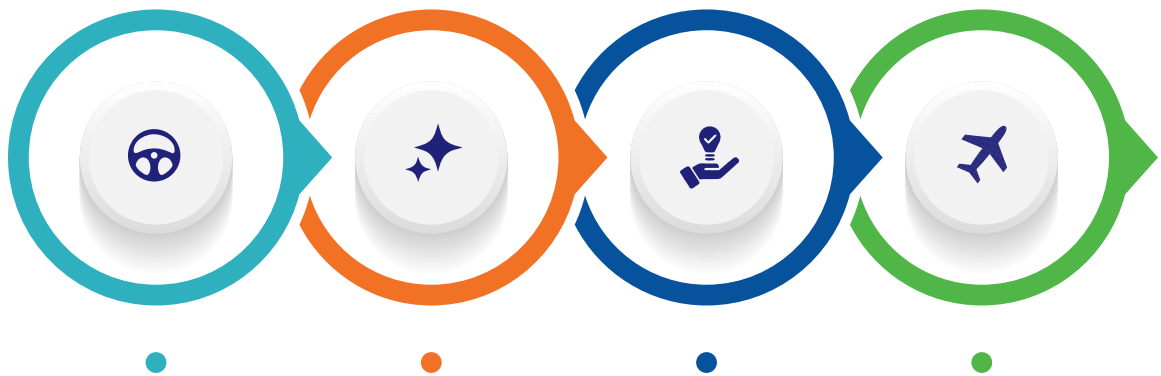

Personalized and Proactive Assistance in Real-Time with Multi Command ability setting a new standard for in-car experience

AI Integration for an Effortless Driving Experience

Enhanced Safety through Intelligent Monitoring Systems

Future-Ready with Upgradable AI Capabilities

With a future-ready, upgradable architecture, our AI-first SDV can easily integrate new features across different vehicle models, providing a scalable, evolving platform for modern mobility. This unique vision combines functionality, safety, and personalized luxury, setting a new standard for connected driving experiences.

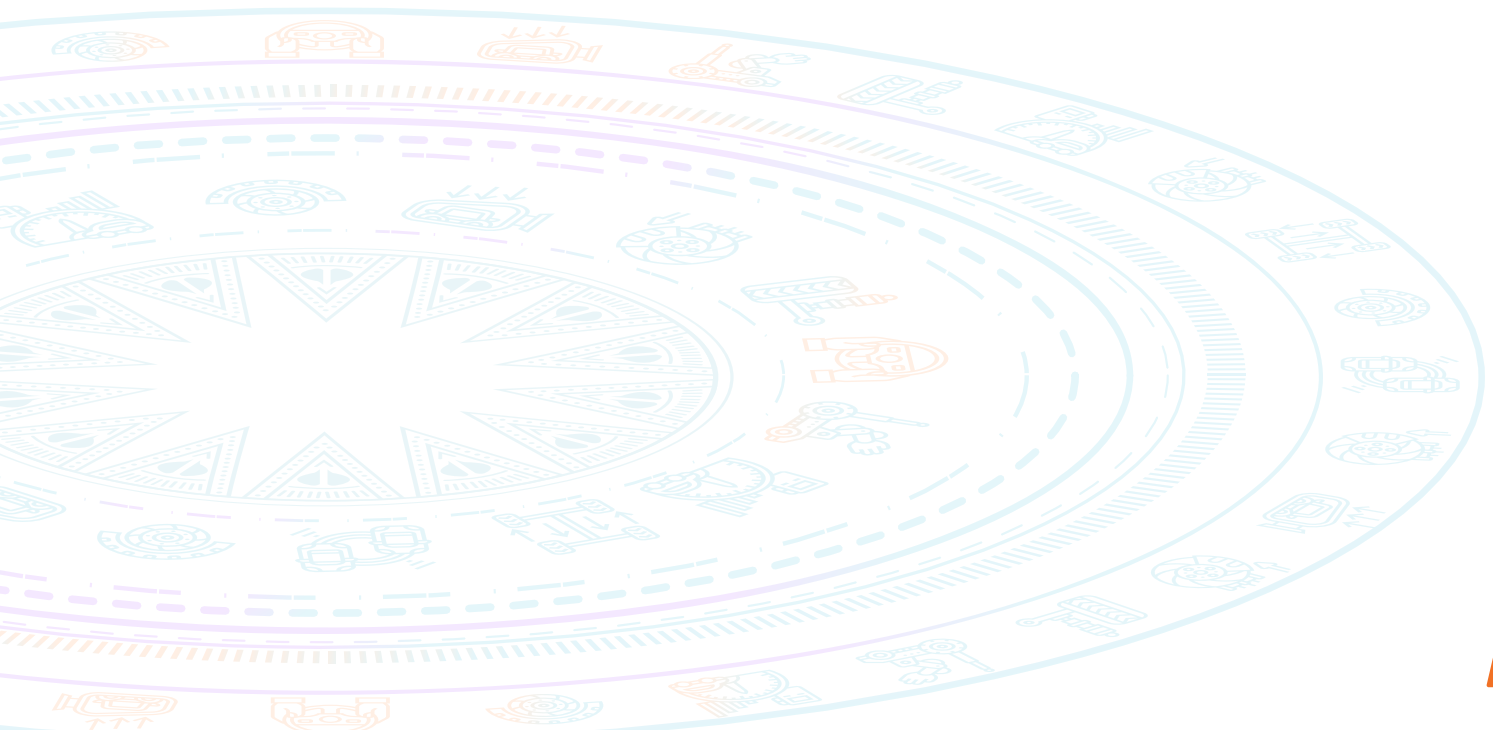

Virtual ECU

THE FUTURE of digital twins is **NOW**

We offer a cost-effective, highly adaptable ECU solution that stands out with its rapid customization, seamless integration with MaaZ_Studio, and user-friendly design for rapid deployment. With dedicated support tailored to clients needs, MaaZ_vECU enables smooth project execution and efficient issue resolution, delivering advanced capabilities



AUTOSAR Development Services

Virtual ECU (vECU)

ECU solution is a tool to generate virtual ECU(s) as FMU of automotive microcontroller software in Software-in-the-Loop (SIL) setups. It provides an early, scalable, cost-effective, and deterministic simulation platform for ECU development, functional test, verification and validation



E/E Architecture

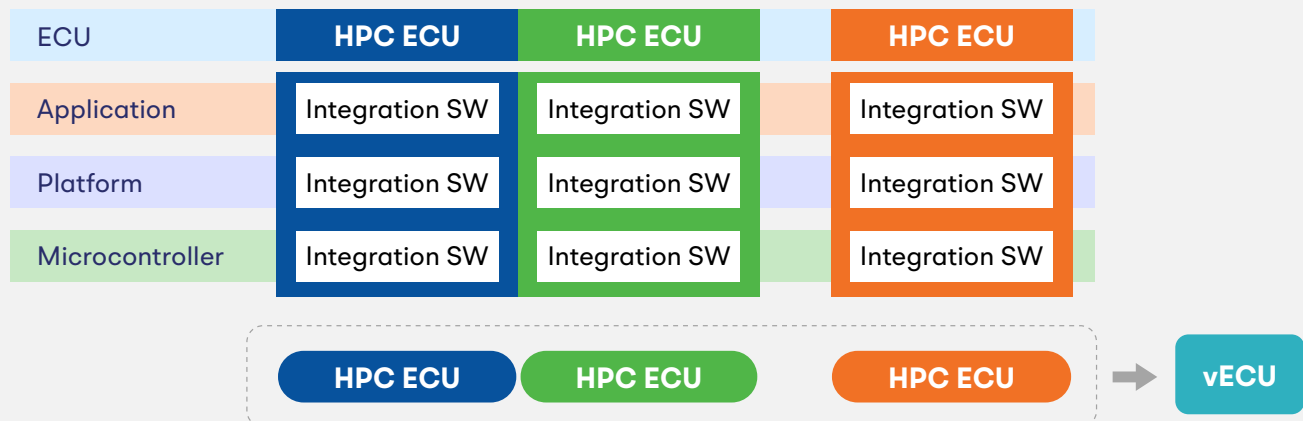

- Generation of Level 1, Level 2, and Level 3 virtual ECUs as FMU.
- Development and validation tasks move from road and hardware rigs to the workstation. Simulations can be done on an individual PC or in parallel on a network.
- Build a vECU from Simulink models, C-code, x86 objects or binaries.
- Run your partial or full-blown production application software and basic software in a virtual prototype.
- Designed for easy collaboration with suppliers and partners.
- For AUTOSAR Classic and Non-AUTOSAR software.



Cockpit Domain Controller

THE FUTURE of in-car experience is **NOW**

As the automotive industry seeks integrated and adaptable digital cockpit solutions, our CDC (Cockpit Domain Controller) offers a comprehensive ecosystem that addresses these demands. Featuring a full suite of digital cockpit functionalities-IVI, cluster, AR HUD, driver monitoring, and surround view monitoring-our CDC solution provides OEMs with turnkey software adaptable to a wide variety of hardware. With dynamic configuration options, it enables flexible, multi-model development, allowing OEMs to deliver a superior, user-centered experience. Complementing the CDC is our ATOA platform, an automated software testing solution that enhances efficiency and reduces costs in the testing process. Designed for multi-platform testing across mobile, HeadUnit, and smart devices, ATOA optimizes hardware resources through Device Farm management, minimizing human resources and accelerating time-to-market. Together, CDC and ATOA form a complete ecosystem from solution to testing, empowering OEMs with a cost-effective, high-quality, and future-ready digital cockpit solution

FPT has been serving OEM and Tier-1 customers for over 17 years with expertise and passion for innovative technologies in AVN, telematics, and cluster systems.

Services provided

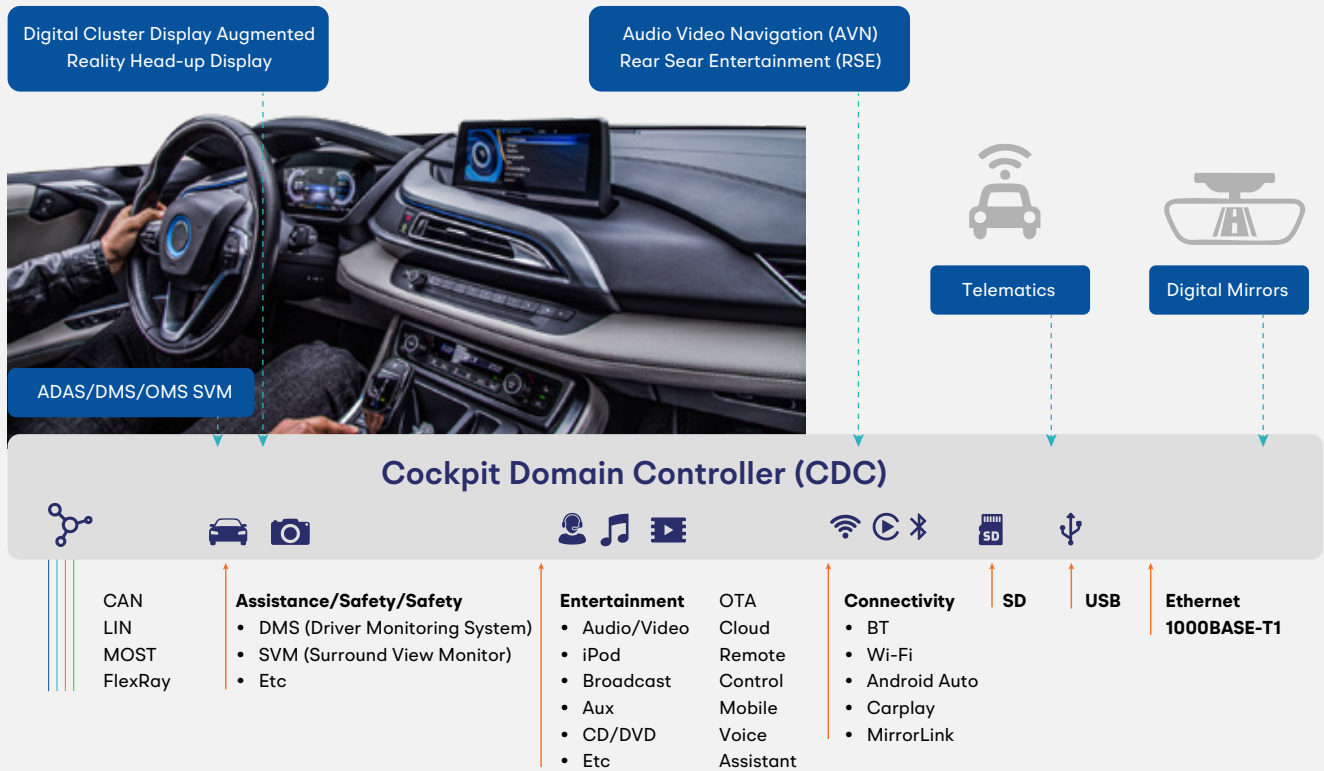

International Certifications

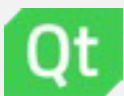

Our solutions are designed to empower you with cutting-edge tools that take your development to the next level. With ready-made options like the Android Automotive Platform, CAN Simulation, and remote automation, we make it easier than ever to control and test your systems in real time, all while leveraging the power of the cloud and AI-driven verification.

But that's not all. Our dynamic configuration solution goes a step further, enabling multi-model development by separating common elements from OEM-specific parts. This approach enhances both reusability and adaptability, allowing OEMs to fine-tune and optimize their designs without starting from scratch each time.



HDF – HMI Design Framework

ACCELERATE

HMI Development with

POWERFUL

Integration Libraries



Your One-Stop Solution for HMI System Development

Imagine having a toolkit at your fingertips, one that simplifies your development process and brings your design vision to life with minimal effort.

You gain access to a vast library of pre-designed 2D and 3D elements, ready to be integrated into your HMI systems. It's not just a collection of resources – it's a fully integrated design system that guides you every step of the way.

All it takes is a quick glance at the documentation, and you're ready to dive in. Drag and drop components where you need them, customize each element to fit your needs, and watch as the updates sync automatically across the system, ensuring everything stays perfectly in sync. It's a seamless process, one that streamlines your workflow and brings the efficiency you've been looking for. Start designing smarter today with HMI Design Framework and unlock a new level of ease in your HMI development.



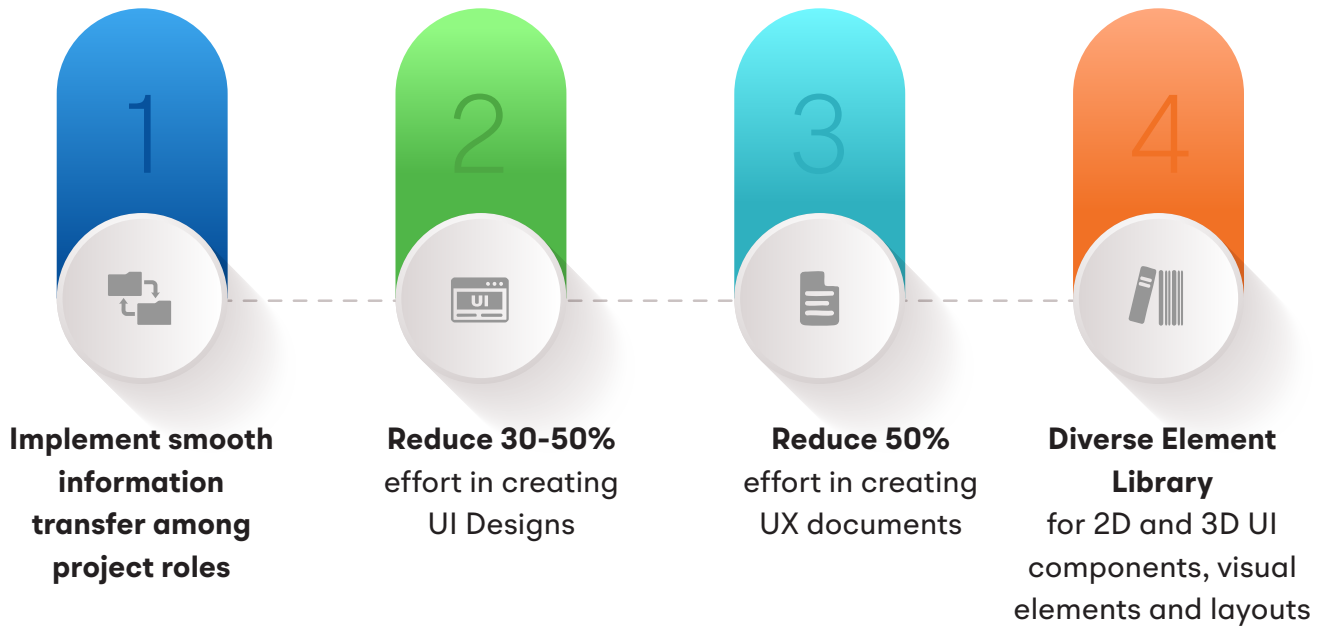

We provide a solution that ensures consistency across all your infotainment systems, delivering a unified look and feel no matter the platform. By offering efficiency through ready-to-use components and comprehensive documentation, we help you save valuable time and resources. Our system also gives you the flexibility to easily customize elements to match your brand identity and specific requirements. Designed with scalability in mind, it allows you to stay adaptable to future design trends and seamlessly integrate with a variety of automotive rendering and graphical engines. And with a rich collaboration toolset, our comprehensive library puts essential information in the hands of your entire team, empowering everyone to work together efficiently and effectively.

Success Stories

■ Business Needs

- Over the past four years in the automotive design field, we have successfully tackled several key challenges:
 1. Converting up to 40,000 screens/project from various formats into a streamlined and intuitive document format for seamless migration.
 2. Innovating new design concepts and scaling them into comprehensive HMI systems.
 3. Delivering effective demo presentations while navigating dependencies on equipment and timing.
 4. Ensuring our designs are compatible with existing technology to avoid costly rework.

■ FPT's Solutions → Outcomes

*The FA Showcase **saves 30% of design processing** time with HDF*

• Solutions

1. Conduct thorough research on HMI systems from trusted and authoritative sources to ensure our approach is grounded in expertise.
2. Develop clear guidelines and categorize system elements into connected libraries.
3. Leverage 3D development tools to creatively visualize design concepts for better feasibility and enhancing innovation.
4. Implement smooth information transfer among project roles for enhanced collaboration.

• Outcomes

1. Establish a unified foundational framework and systematize components within the HMI system.
2. Enable automatic updates for all relevant changes. Saving 80% change request processing time.
3. Maximize efficiency and minimize testing time on real devices by leveraging 3D simulations on equivalent devices.

Ensure accurate and clear communication across project roles.

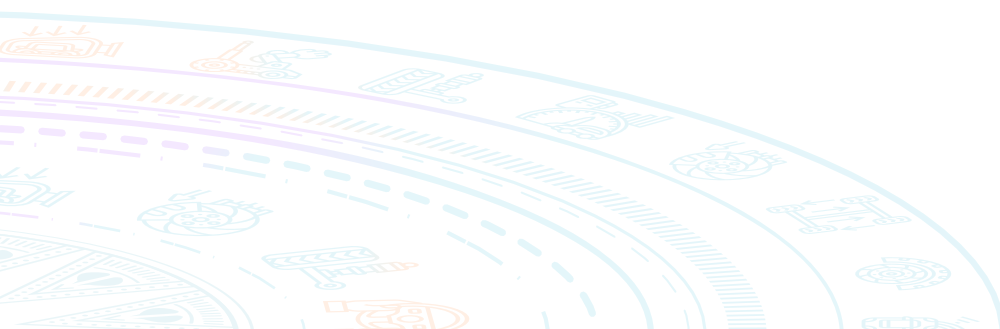

Electric car | System
Electric motor - 3DI 320V
Self-driving system is activated
The car is protected.

Traffic-Aware Cruise Control
Activated
Assists in moving to an adjacent lane on the highway
when Autosteer is engaged.

ATOA

THE FUTURE



of automotive testing is **NOW**

In a fast-evolving automotive landscape driven by cutting-edge technologies, the demands on your organization are higher than ever. Meeting these demands requires a seamless release pipeline for your automotive devices, where testing keeps pace with the speed and complexity of your development cycle.

At FPT Automotive, we understand that innovation waits for no one. We're here to ensure your testing process is as advanced, agile, and reliable as the solutions you create – so that you can focus on what you do best: shaping the future of mobility.

ATOA is redefining automotive software testing with a complete suite of hardware and software tools designed to accelerate and enhance the quality of testing processes. Our tools bring unmatched flexibility, visibility, and actionable insights, enabling your team to achieve continuous testing excellence and confidently tackle the industry’s toughest challenges.

Imagine a testing solution that’s accessible to everyone, regardless of coding experience. With ATOA, automated testing is within reach for all, empowering teams to execute efficient, high-quality tests without needing to write a single line of code. This innovation boosts productivity, reduces costs, and guarantees superior results, setting a new standard in automotive testing.

01	02	03	04
 <p>Customization</p> <p>Our customization service tailors ATOA to your systems and needs with flexible components, integrated options, and multiple deployment choices.</p>	 <p>Generative AI Testing</p> <p>Harnessing Generative AI, ATOA automates testing processes by creating intelligent test cases and scenarios, enabling faster and more precise quality assurance.</p>	 <p>High security</p> <p>Install ATOA on your private servers for full control over your data and interface, or opt for the secure Cloud SaaS. With the SaaS edition, launch your test project in minutes and enjoy automatic updates for a fast, seamless experience.</p>	 <p>Competitive testing cost</p> <p>Cut testing costs by over 50% and slash execution time by 70%</p>

ATOA

ATOA is a flexible software suite tailored to fit your workflow. Choose and deploy the products and components you need, either on your servers or via our cloud. With customizable plans for any budget, installation, or security requirement, ATOA adapts to your goals - giving you control, flexibility, and confidence to innovate.

Device Farm

Enables remote access to a wide range of Android and Linux-based automotive devices, allowing you to develop and test applications tailored for in-vehicle systems efficiently from anywhere

Automation

Graphical tool for designing test scenarios. Enables you to deploy automation tests on a larger scale, faster and more efficiently.

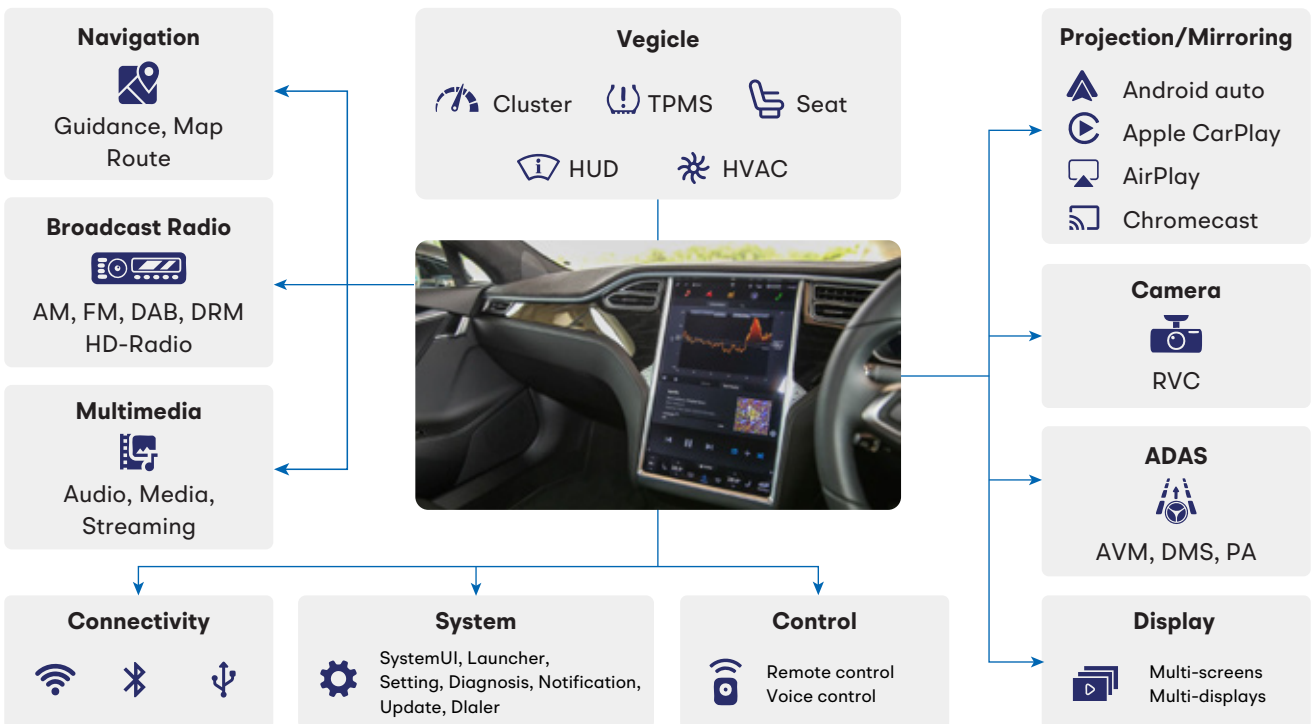
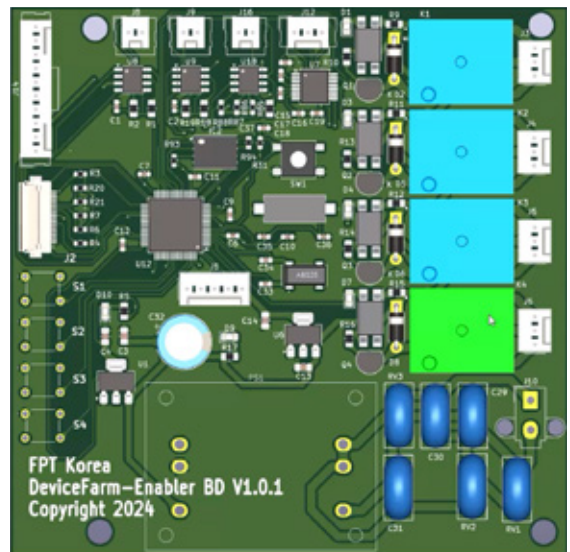

ADAS/AD

AD Development Service

ADAS: Autonomous Level 2.5

- Auto Parking
- Surround View Monitoring
- AD level 2.5
- Cloud Platform/Fleet Management
- Data Labeling
- In-car payment using nextface (faceid) + VoiceDNA (voiceid)

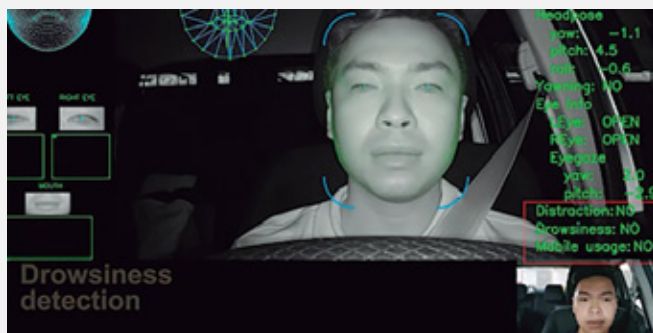

Driver Monitoring System (AI/Edge Computing)

- Driver Profile
- Face Activity
- Drowsiness Detection
- Distraction Detection
- Dangerous behavior
- Child & Pet Presence

AI: Visual and Sound Inspection

- Battery Cell Inspection
- Auto Parts Crack Detection
- Surface Defect Detection
- Solar Panel Inspection
- Leak Detection
- Anomalous Sound Detection





■ Case Study

Yamaha electric golf cars, upgraded with **FPT Automotive's latest self-driving technology**, conducted self-driving demonstrations without human intervention at the following locations:

- Ecopark, an eco-city located 20km east of Hanoi
- Hi-Tech Park Campus, District 9, Ho Chi Minh City
- FPT Complex Campus in Da Nang

These vehicle functions correspond to **Level 3 autonomous driving** as defined by the Society of Automotive Engineers (SAE).

In the self-driving demonstration, a Yamaha electric golf car, upgraded with FPT Software's latest self-driving technology, **drove a four-kilometre length without human intervention.**

Five bus stops and intersections have been installed along this route to prevent vehicular movement.

When a user registers for self-driving via a mobile app, the vehicle **automatically calculates the best route and prioritizes passengers** in chronological order.

It was also able to detect and avoid obstacles and vehicles along the route, and was able to pick up and drop off passengers with 100% accuracy. Once there were no passengers, the vehicle returned to its starting point and parked itself using the **automatic parking feature.**

Automotive Digital Services



V2X & Telematics

Central hub for vehicle connectivity, enabling smart communication through 5G and facilitating real-time vehicle-to-everything interactions

OTA

Seamless vehicle upgrades are delivered wirelessly, bypassing the need for traditional dealership service appointments



ADAS & Active Safety

ADAS and active safety technologies prevent accidents, enhancing vehicle control and driver assistance for safer driving

Personalization, Audio & Infotainment

Systems that revolutionize in-car experiences with customized settings, high-quality sound, and diverse media options



Complex Controllers & Control Systems

Manage intricate vehicle functions, ensuring efficiency, reliability, and advanced performance

Electric Car

Advancements focus on efficient battery management and widespread, accessible charging station infrastructure.



EV Development Services

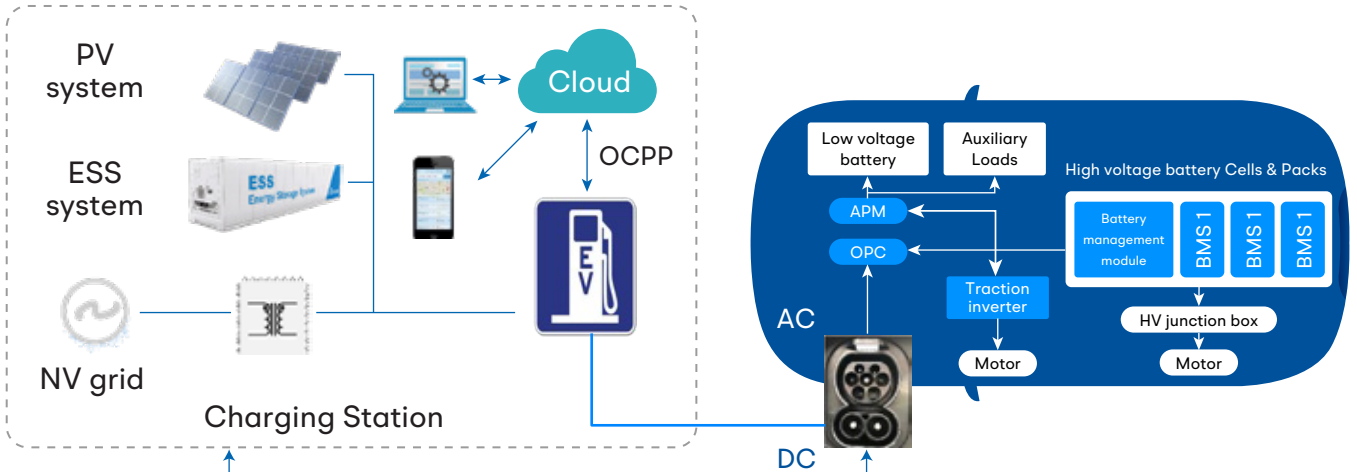

- Target components in charging station :
1. DC Fast Charger
 2. ESS (Energy-Storage System)
 3. Photovoltaic system

- Target components in EVs :
1. OBC (On-board Charger)
 2. APM (Low voltage DC-DC)
 3. PDU (Power-Distribution Unit)
 4. Traction Inverters
 - BMS (Battery Management)

- Other components:
1. Battery testing system
 2. Wireless Charging system

Our strengths

Leveraging our extensive experience in developing charging management system, we help our partners with seamlessly creating smart charging management solutions.

- Scalable and future-proof software
- Best-in-class technology coupled with real experience to shorten time to market
- Cost optimization

THE FUTURE OF DRIVING IS NOW



47000
Charging session realized in one month



8000
Charging points connected with the solution in 27 countries



70
Releases with continuous improvement and extensions



05
User interface is developed in 5 different languages



SAFe
Methodology
More than 20 teams in different areas (BackEnd, FrontEnd, DevOps)

Mechanical Services

We enhance our customers' business efficiency and quality through rapid response from a vast team of experienced engineers with a proven track record spanning diverse industries. Leveraging offshore services, we also ensure high cost-effectiveness.

Services provided

CAD

- CAD data conversion
- 2D/3D data modeling
- Support for component, assembly design
- Create documents
- Undertake all development phases
- Automate CAD operation

CAE

- Create FEM model
- Create coupled model
- Analyze single item performance
- Analyze overall product performance
- Automate CAE operation

A wide range of target areas

- Automotive
- Machine component
- Construction machine, etc.
- Bike
- Railway
- Agricultural machine
- Heavy machine

Main tasks

Motorbike

- Detailed design of resin parts
- 3D modeling
- Strength and durability analysis

Car

- Engine, PT, body, interior
- Exterior design
- 3D/2D modeling/drawing creation
- Creation of design documents
- Single item/Unit analysis
- Vehicle performance analysis (crash, strength/ durability, NVH, aerodynamics)
- HEV/BEV Battery Pack structural analysis

Flexible working model

- Support onsite work in customer's office and offshore work collaborated with Vietnamese office.
- Handle all communications with customer in Japanese.
- Full security support with entry/exit, terminals, networks, services, etc.

Train

- Modeling engine parts
- Handle/switch modeling
- Creation of 3D/2D drawings
- Product testing

Machine parts

- Creating airplane parts data
- Detailed design of printer parts
- 3D modeling of automatic door parts
- 3D modeling of production equipment

Functional Safety/Security

Services provided

A-SPICE fulfillment

- Process
 - Gap analyses
 - Process establishment support Traizing & deploy the process
 - Support to successfully achieve a target maturity
 - Conduct appraisals with experienced authorized assessors
 - Implement comprehensive improvements programs
- Engineering
 - SW Unit Test/Static Check and Integration
 - Test Create detailed design documentation
- Consulting, Training and Coaching

Cyber security

- Testing: Architecture and Code Review, Unit Test, Static Code Analysis, Functional Tests, Fuzz Testing and Penetration Test.
- Secure platform: Secure Boot, Secure Flash, Crypto stack, and HSM
- Secure in-vehicle communication
- Secure OTA

Functional safety

- Safety Management
 - Document reviews
 - FMEA reviews
 - Document inspections
 - Process inspections
- Safety Engineering
 - Concept phase (Item Definition, H&R etc.) System architecture
 - Software architecture Security analyses (e.g., FTA, FMEA)
 - Functional Safety concept
 - Technical Safety concept
 - Requirements Engineering
- Consultant and Training
 - Fundamentals
 - Management Concept phase
 - System level
 - Software level Production & Operation
- ISO 26262 Compliant Automotive ECU Testing
- ISO 26262 Compliant Automotive Software Development

■ Representative Case Study

Challenges

- The existing AUTOSAR vendor couldn't fulfill customer's requirements for developing in-vehicle safety and security software
- The OEM needed a new partner like FPT who could meet their business requirements, such as technical quality, cost reduction, and speed to market.

Solutions

- Developed 3 vehicle functions in the ECU
- Built 2 products for 2 different OEMs in parallel
- Completed 11 test levels from software unit to integrate into CI chain
- Successfully ran the application on three core plus HSM (Hardware Security Module)
- Integrated 10 security controls

Values

- Reduce 70% labor cost
- Resolved the OEM's AUTOSAR talent shortage: 10 FPT engineers plus 1 from the OEM collaborated to form a system safety and security team of 80 engineers.
- Reduced time to market: Product release on vehicle every 2 months

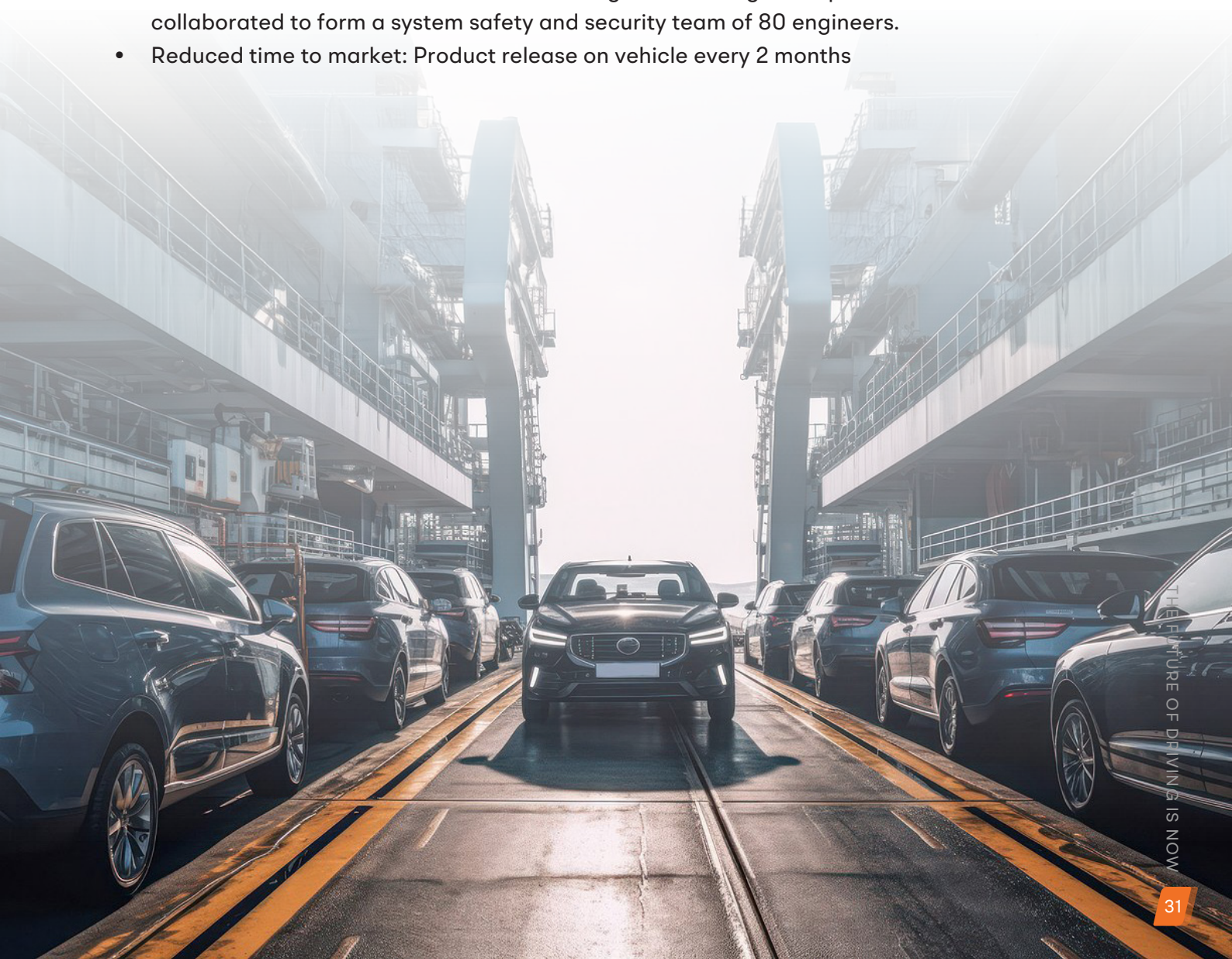

A decorative graphic element consisting of several overlapping, curved, swoosh-like shapes in shades of orange and yellow, positioned in the upper right quadrant of the page.

FPT Automotive is more than a partner; we're a driving force at the forefront of the automotive industry's evolution. Our vision is clear and unwavering: to be the trusted partner that empowers your journey into the future of driving. With dedication and commitment, we move in step with our clients, forging paths that turn today's challenges into tomorrow's opportunities. Together, we're not just adapting to change - we're actively creating it.

Every solution we develop, every innovation we pursue, is rooted in a deep understanding of our clients' needs and the future they envision. We're here to grow with you, to collaborate in meaningful ways, and to push the boundaries of what's possible. Because for us, the future of driving is not a distant horizon - It's here, and it's now.